



100 Sterling Mine Rd
Sloatsburg, NY 10974
Ph:(845) 357-5718
www.apexcanopies.com

CANTILEVERED CANOPY

PRODUCT SPECIFICATIONS

CANTILEVERED CANOPY PLAN VIEW

Scale: 1" = 1'



100 Sterling Mine Rd
Sloatsburg, NY 10974
Ph:(845) 357-5718
www.apexcanopies.com

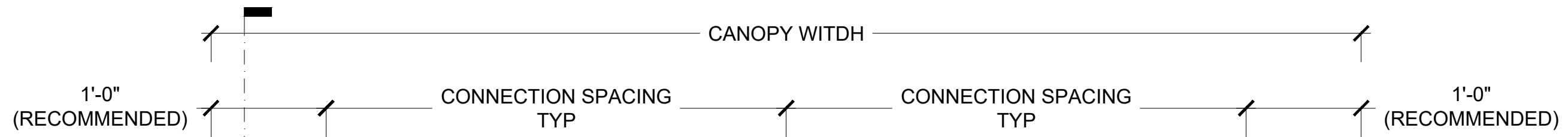

Project # :

-

Project name :

CANTILEVERED CANOPY

Title:

CANTILEVERED CANOPY

DWG by: CD

Date: 12/02/2024

CHK by:

Date:

REVISIONS

REV#	DATE	DET BY	CHK BY

NOTES

SCALE:

As noted

SHEET

01 of 06

3"SQ. DOWNSPOUT

CANOPY PROJECTION
(5'-0" MAX
RECOMMENDED)

3" X 2.33 X .260 X .170
S3x5.7# S-BEAM

3" X 6" X 0.065" 6063-T6
SELF MATING ROOF PAN(FLAT FINISH)

4" X 8" X 0.125 6063-T6
GUTTER FASCIA

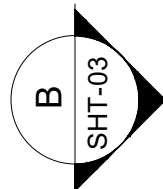
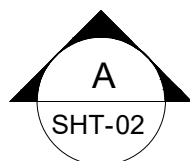

Section A
Scale: 1" = 1'-0"

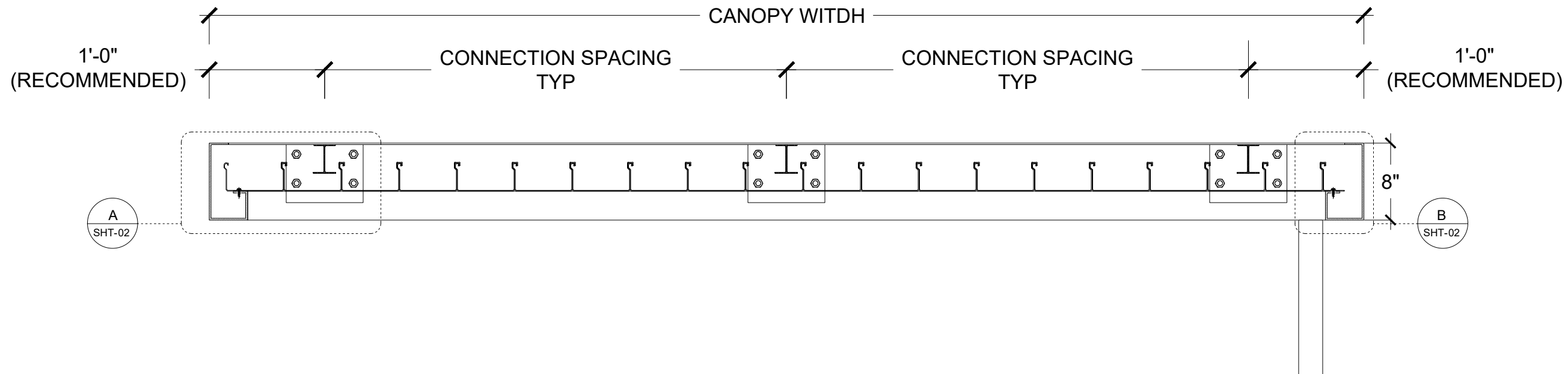

Detail A
Scale: 3" = 1'-0"

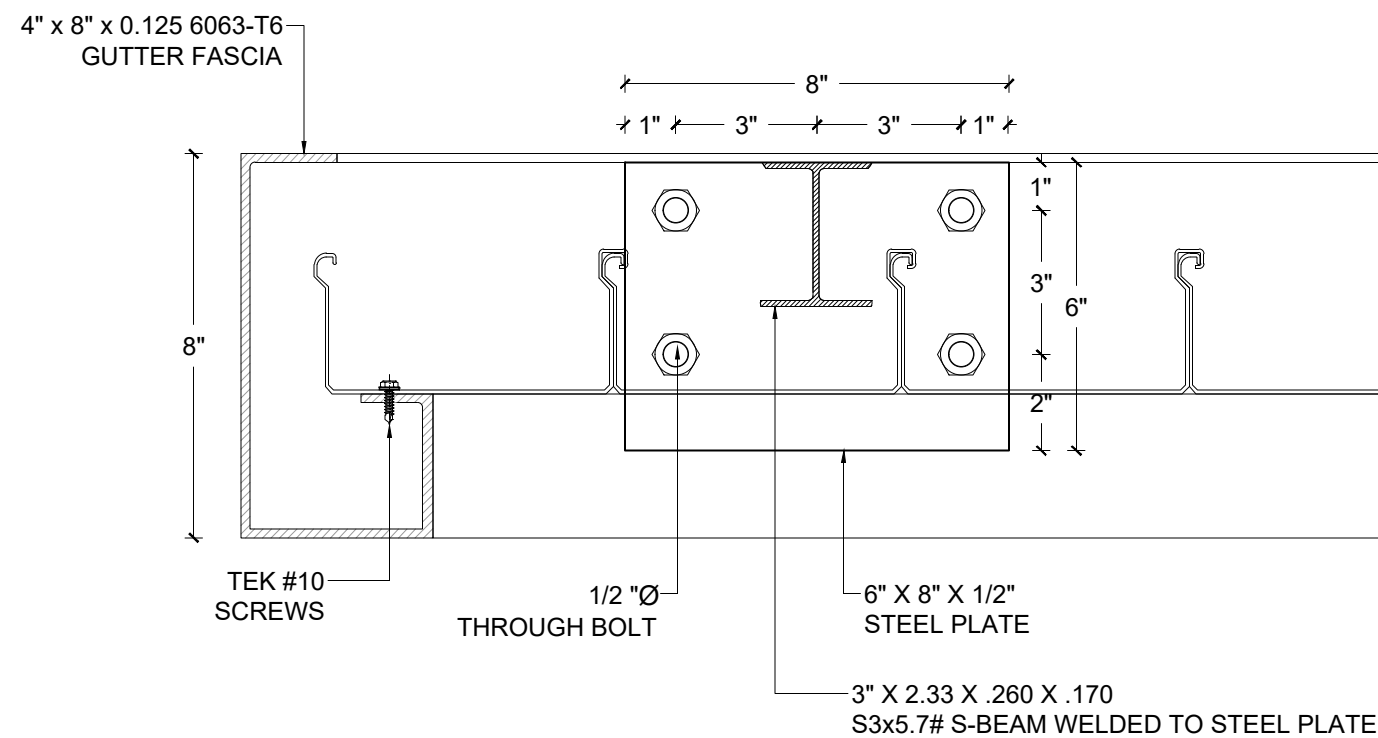

NOTE: GALVANIZED SEPARATION FOR DISSIMILAR MATERIALS

Detail B
Scale: 3" = 1'-0"

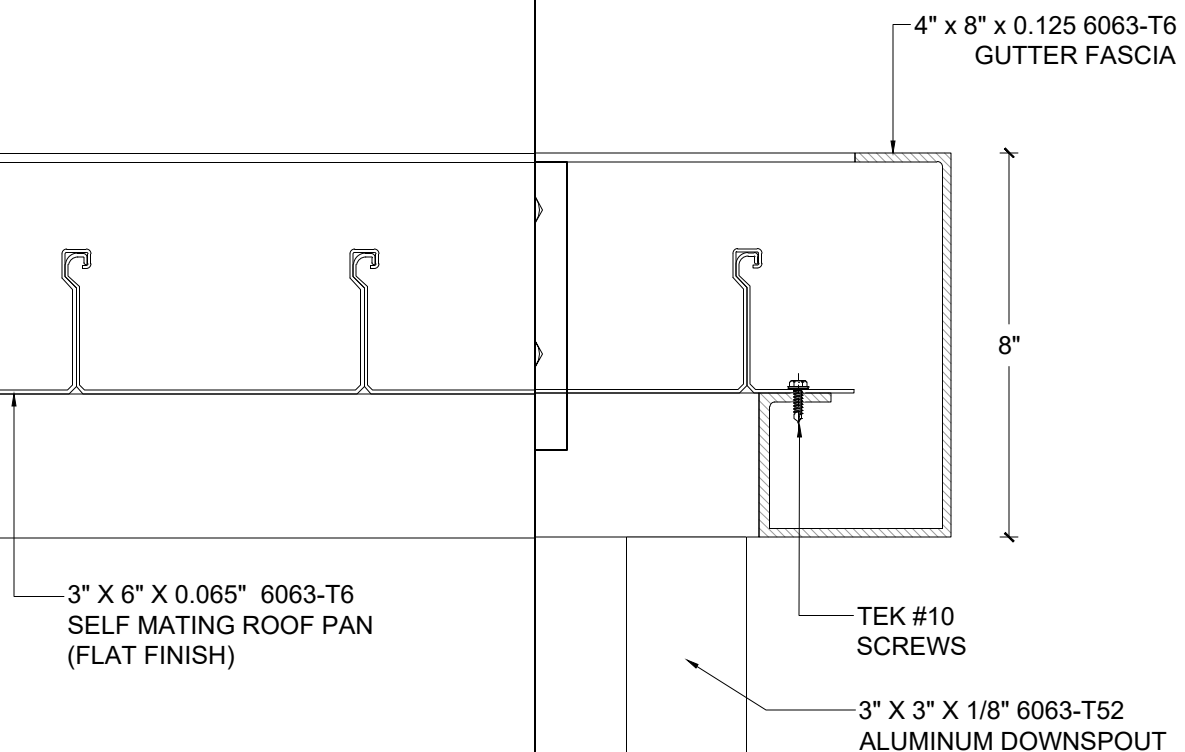

100 Sterling Mine Rd
Sloatsburg, NY 10974
Ph:(845) 357-5718
www.apexcanopies.com

Project # :

Project name :

CANTILEVERED CANOPY

Title:

C1-SECTION DETAILS 1

DWG by: CD

Date: 12/02/2024

CHK by:

Date:

REVISIONS

REV#	DATE	DET BY	CHK BY

NOTES

SCALE:
As noted

SHEET
02 of 06

B

Section B

Scale: 1 1/2" = 1'-0"



100 Sterling Mine Rd
Sloatsburg, NY 10974
Ph:(845) 357-5718
www.apexcanopies.com

Project # :

Project name :

CANTILEVERED CANOPY

Title:

C1-SECTION DETAILS 2

DWG by: CD

Date: 12/02/2024

CHK by:

Date:

REVISIONS

REV#	DATE	DET BY	CHK BY

NOTES

SCALE:

As noted

SHEET

03 of 06

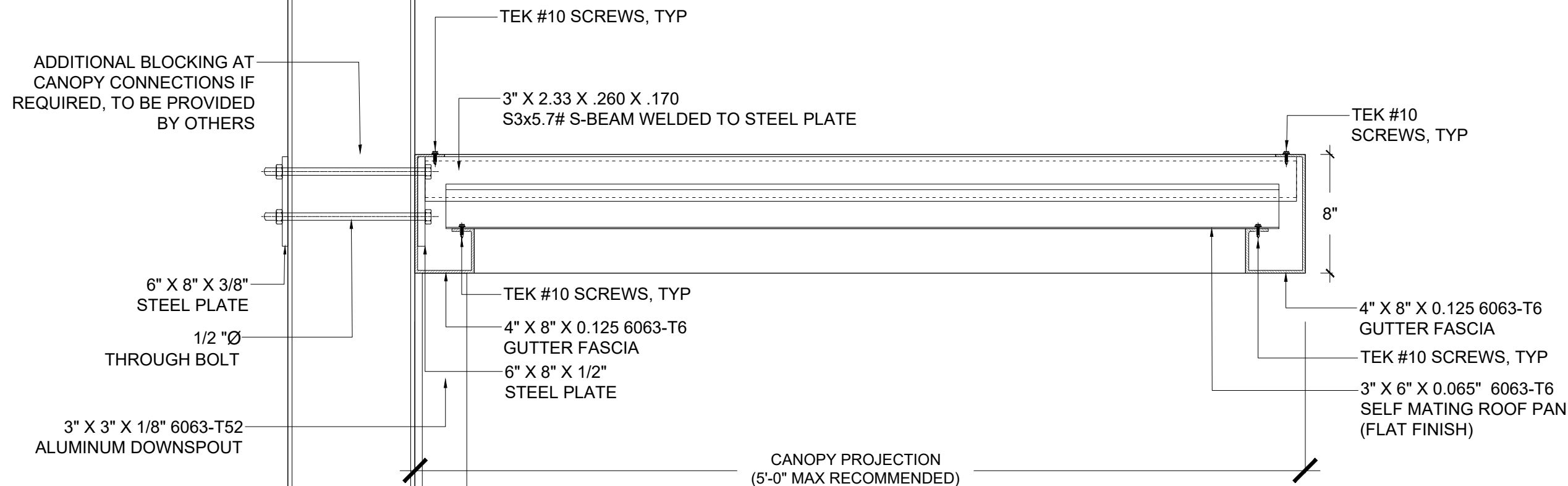

NOTE: GALVANIZED SEPARATION FOR
DISSIMILAR MATERIALS.